



Tango & synoptics

Fabio Asnicar

TANGO Meeting @ELETTRA

Trieste 17-18 April, 2008

scenario

- to perform data collection and control at the supervisory level of large-scale (geographical) distributed systems
 - functional view: relationship between physical components (e.g. a circuit)
 - logical view: relationship between entities
 - spatial view: geographic information

functional view

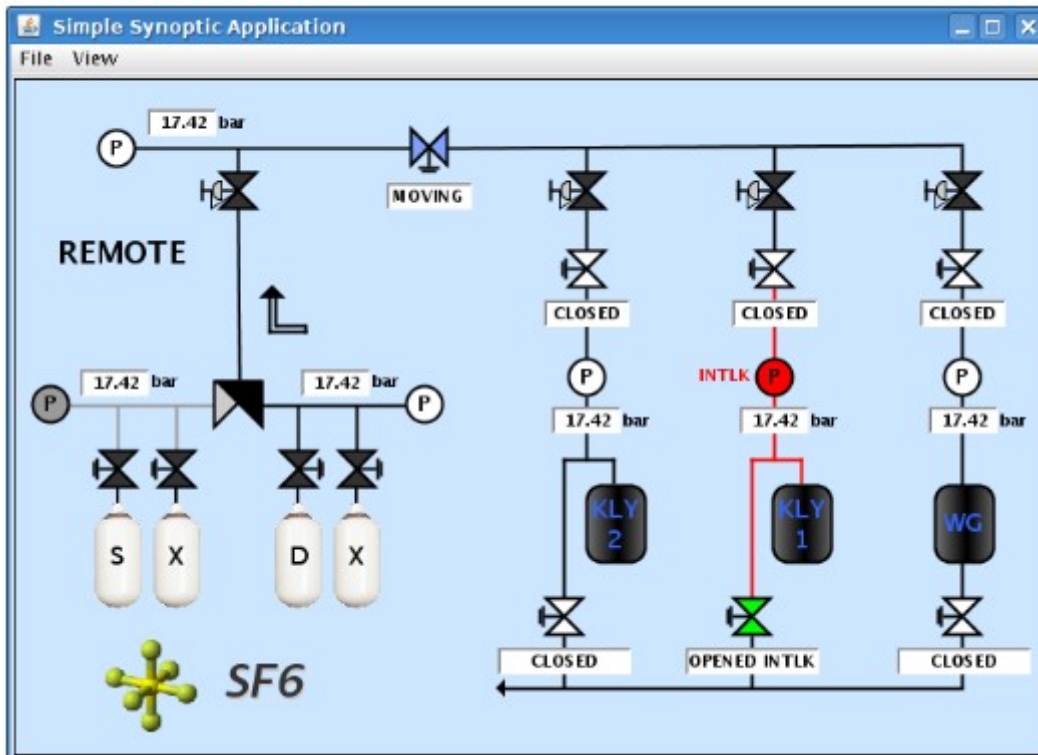

- The Sulfur hexafluoride system: some cylinders, a flux deviator, some valves, and some manometers ...
- JDraw & images & time

logical view

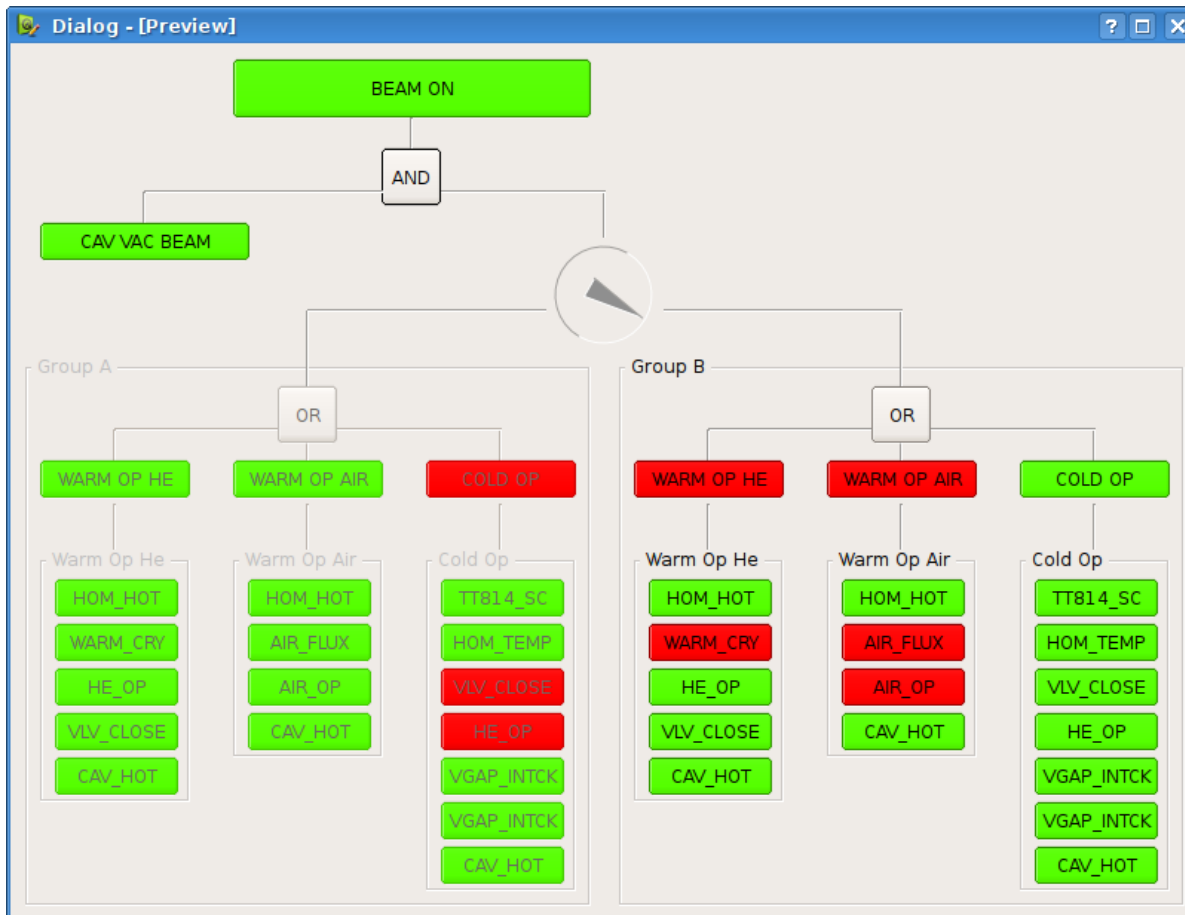

- relationship between the (status of) entities
- logical dependencies
- attributes, status, AND, OR, switch, ...
- Qt

spatial view

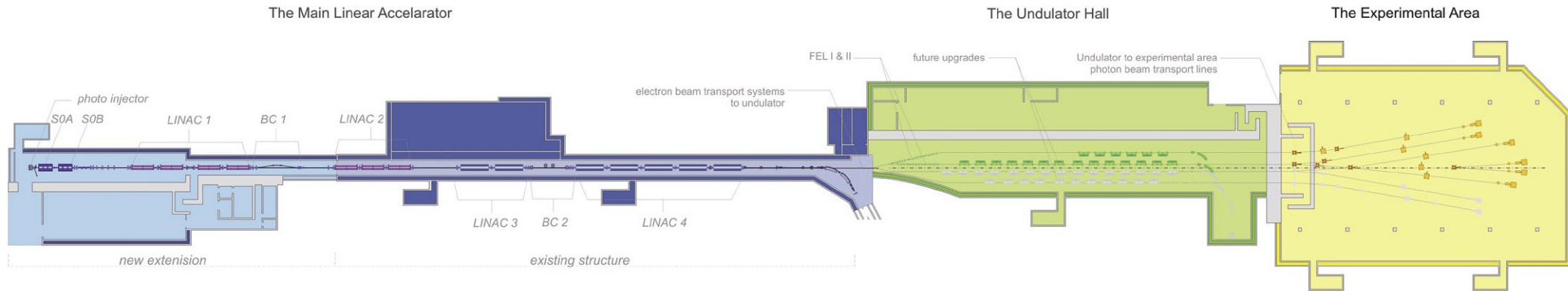

- FERMI machine
- All in one big image ...

(generic) use case

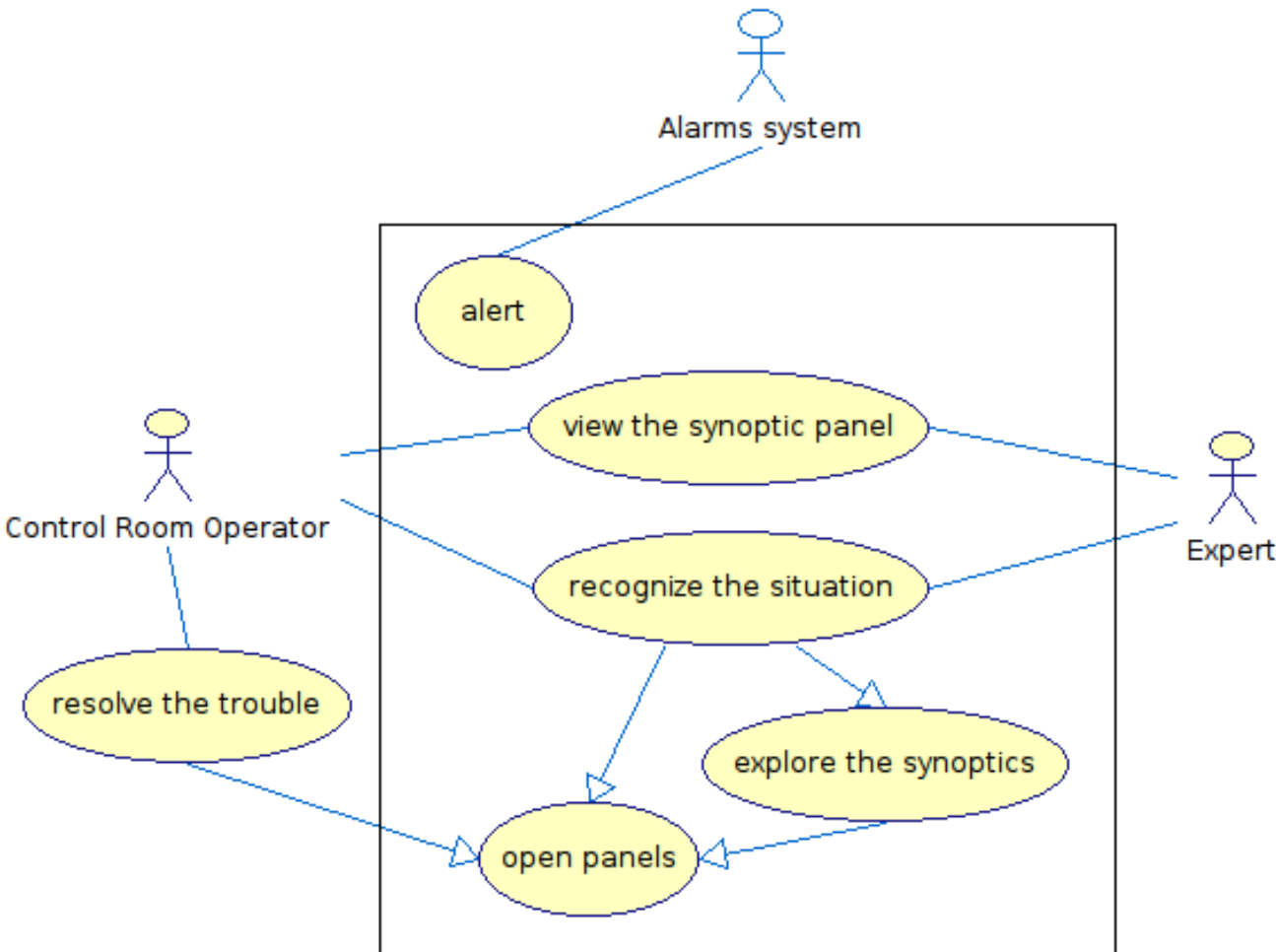

- the operator can/must recognize the situation in a rapid and effective way
- explore the (hierarchy of) synoptics, work with *traditional* panels too
- other users can interact with the same resources

booster magnets

How to show all the necessary?

PUL_EME

PWR_SUPPLY_ABI

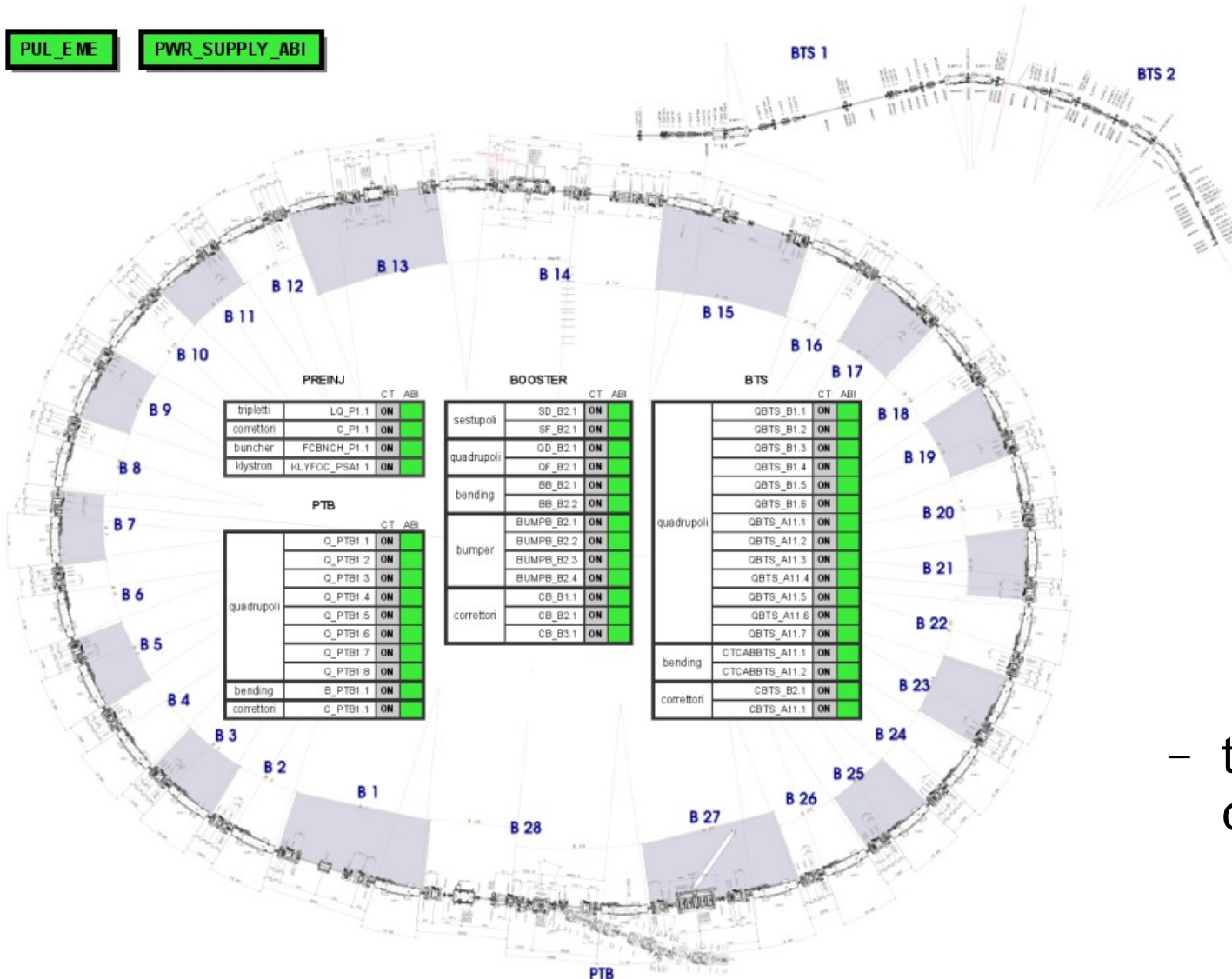

- 24 sextupole
- 36 quadrupole
- 28 bending
- correctors, bumper, ...
- ~45 power supply

– there are too many components!

booster magnets

PUL_EME

PWR_SUPPLY_ABI

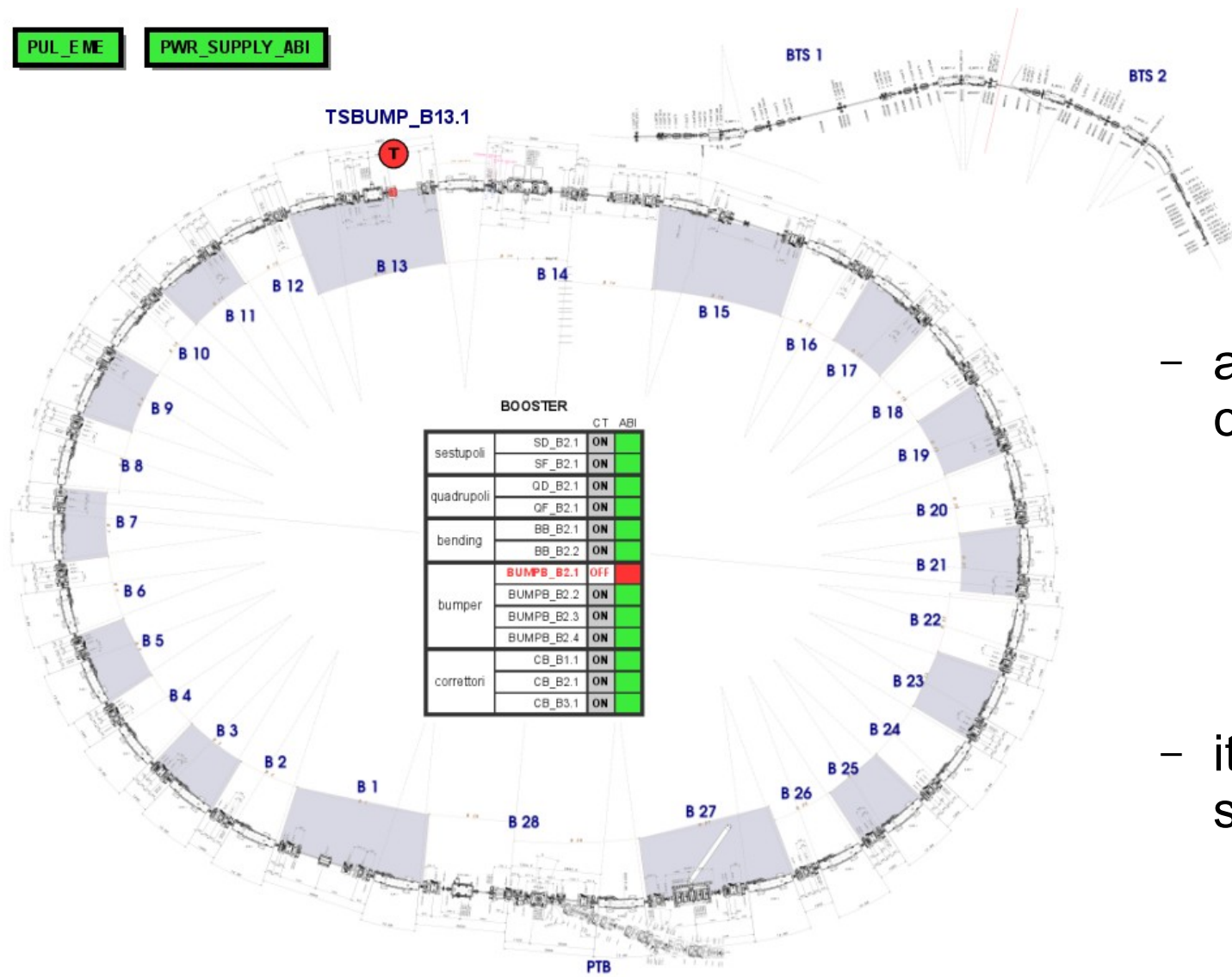

– alarm status, a simple case:

- a bumper
- one sensor
- one PS

– it is not easy to locate a single magnet in the ring

booster magnets

How to hide the unhelpful info?

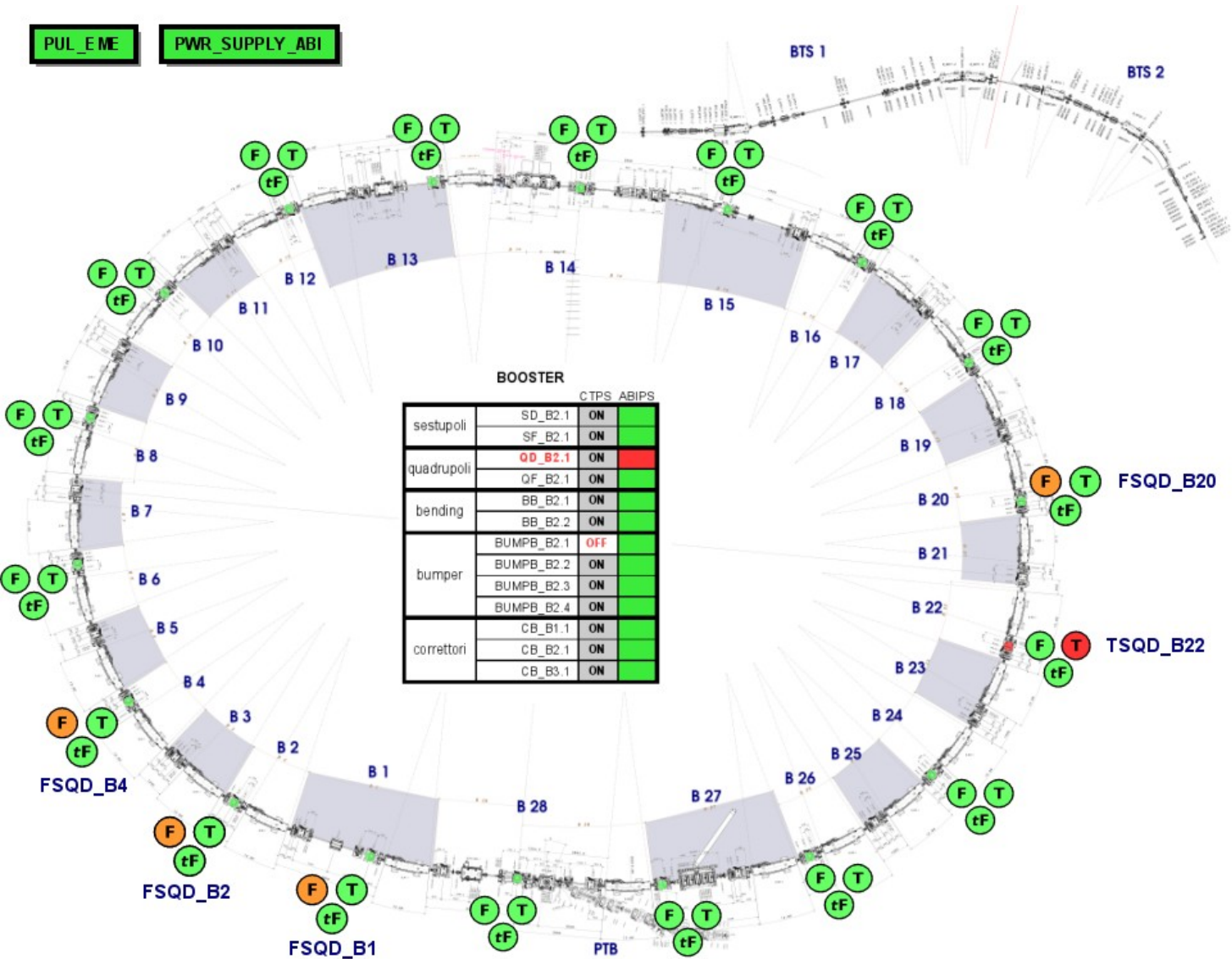

- alarm status:
 - n magnets
 - m sensors
 - one PS
- each component has more than one sensor: it is not possible to show all of them in the same panel!

supervisory level

How to bring all together?

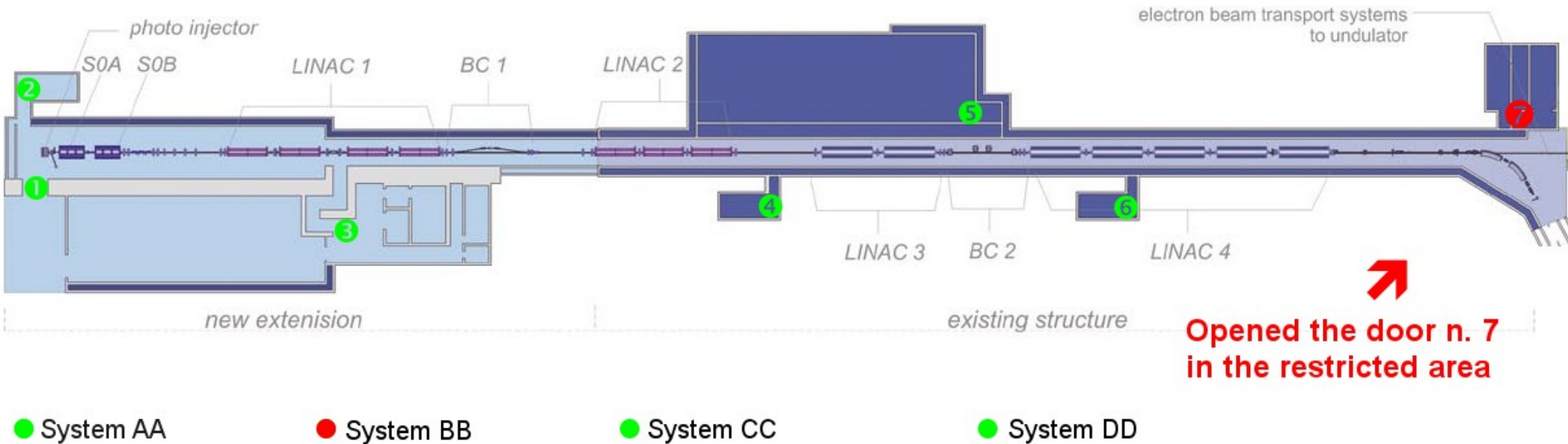

FERMI main linear accelerator

- part all the system from a functional point of view (vacuum, magnets, ...), and perhaps organize all the components inside a subsystem in a *logical* hierarchy
- a single alarm from one subsystem

FERMI main linear accelerator

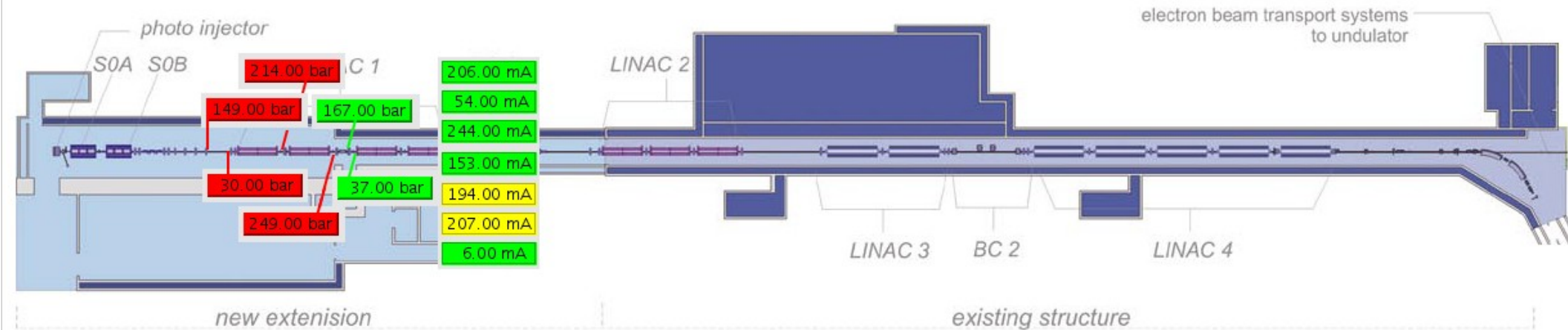

● System AA

● System BB

● System CC

● System DD

- a set of alarms from one subsystem
- ... perhaps it is better to zoom in

FERMI main linear accelerator

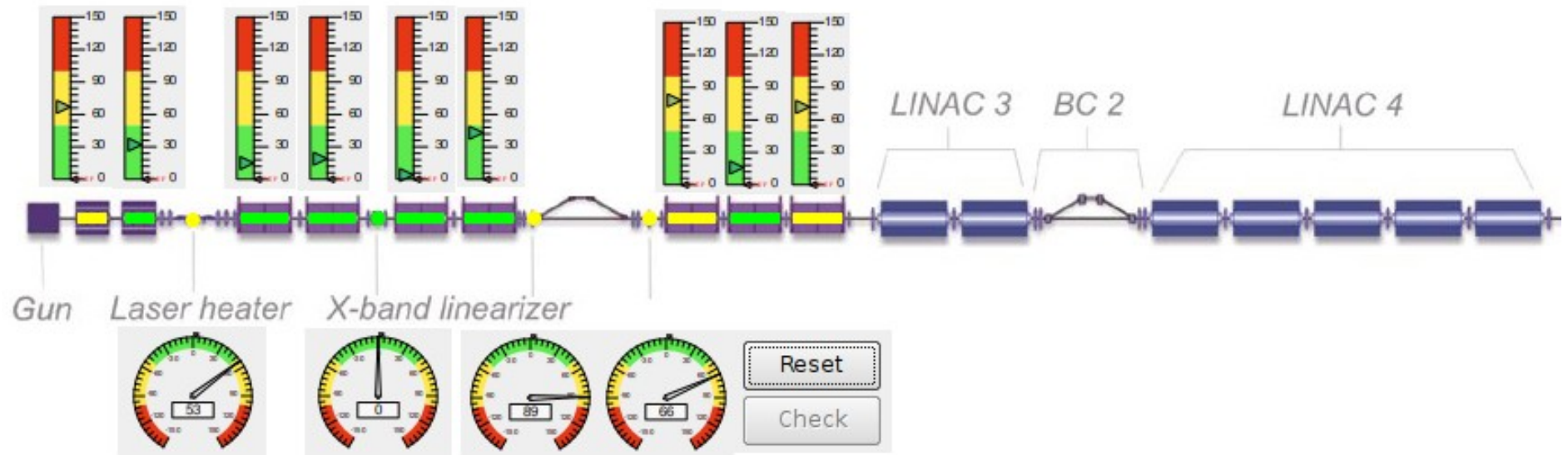

- explore the synoptic panel: zoom on part of it

FERMI main linear accelerator

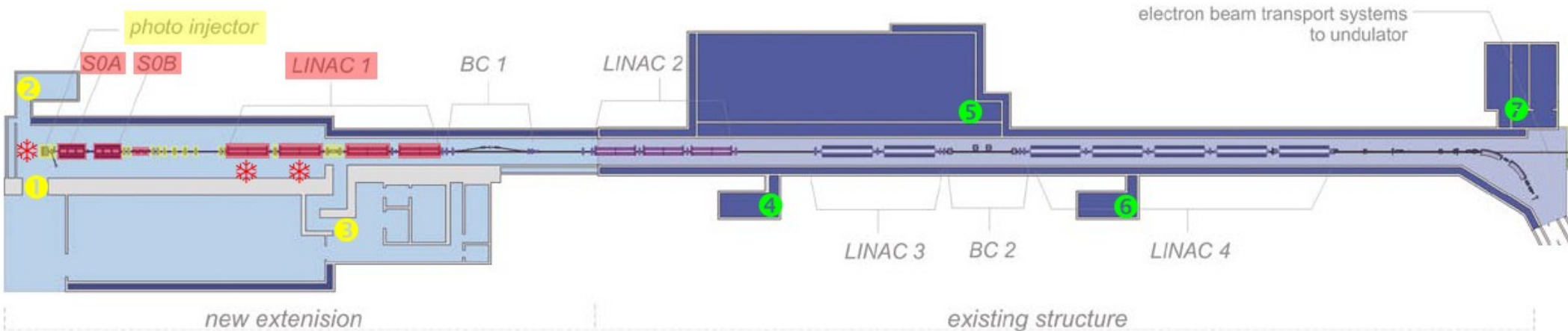

● System AA

● System BB

● System CC

● System DD

- a set of alarms from more than one subsystem (possible area problem)

... ?

matrix

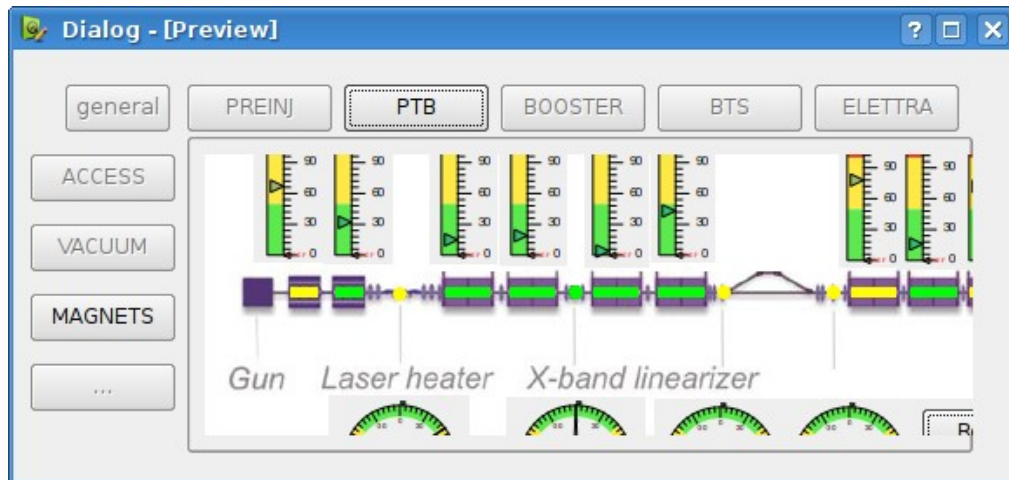
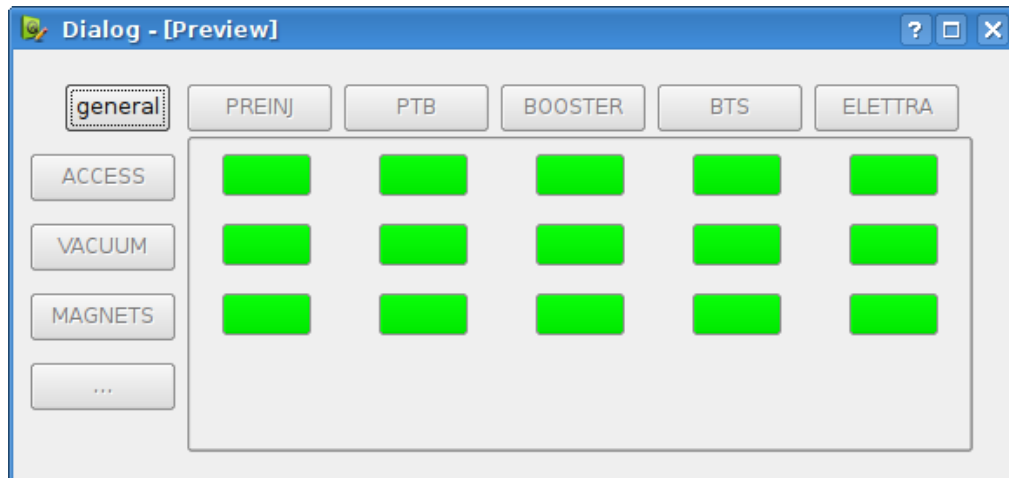

x= spatial view
y= functional view

- general view
- specific view for each column or row
- a specific synoptic (if it makes sense) for each cell of the matrix

questions

- how to show all (the necessary)?
- how to hide the unhelpful information?
- how to bring all together?

- Jdraw, Qt, SVG, ... ?
- ATK, qtango, ... ?

answers



17 April, 2008
16 / 16

TANGO Meeting @ELETTRA - Tango & synoptics



(the end)

thanks

fabio.asnicar@elettra.trieste.it



17 April, 2008
17 / 16

TANGO Meeting @ELETTRA - Tango & synoptics

